

ADVANCE ADAPTERS INC.

P.O. Box 247, 4320 Aerotech Center Way
Paso Robles, CA 93447

Telephone: (800) 350-2223 Fax: (805) 238-4201

P/N: 715596

New Item: (11/10)

PAGE 1 of 7

Page Rev. Date: 12-10-15

JK CABLE SHIFT LINKAGE UPGRADE KIT

KIT CONSISTS OF:

No.	Qty	Part No.	Description
1.	2	303313	HEIM JOINT - FEMALE 1/4"-28
2.	2	340615	BOLT - 1/4"-20 X 5/8" B.H.C.S
3.	1	42R725-1	SHIFTER CABLE - 2" TRAVEL
4.	24	42R726	HEAT SHIELD-FIREPROOF SLEEVE 1/2"
5.	2	42R735	BOLT 1/4"-20 X 1" H.H.C.S. GRD 8
6.	1	42R740	BOLT 8mm X 1.25 X 14mm H.H.C.S.
7.	1	715596A	PIVOT ASSEMBLY
8.	1	715596A1	PIVOT BLOCK
9.	1	715596B	BRACKET-CABLE MOUNT
10.	1	715596C	LEVER - TRANSFER CASE
11.	1	715596E	SPACER - TRANSFER CASE LEVER
12.	5	722514	NYLON LOCKNUT 1/4"-20
13.	1	722523	1/4" USS FLAT WASHER PLTD.
14.	1	722530	1/4" X 20" X 3/4" S.H.C.S.
15.	2	722532	1/4"-20 X 3/4" H.H.C.S. GRD 5
16.	1	722543	1/4" X 20" X 1-1/2" S.H.C.S.
17.	2	726207	5/8" FLAT WASHER SAE OD
18.	1	29-2004	YOKENUT

Assembly video of this product found at (<http://www.youtube.com/watch?v=5OrMzFQ2ssg>).

Notes:

The stock Jeep linkage uses plastic heim joints and a light duty shifter cable. The shifting of this transfer case and stock linkage puts wear and tear on these shifter components and eventually will wear them out. Our new cable upgrade keeps all the stock interior look and provides a positive shifting assembly that will provide a great addition to your Jeep JK.

This kit replaces the stock Jeep cable assembly with a heavy duty push/pull cable equipped with quality steel heim joints providing you a reliable linkage assembly.

SPECIAL NOTE: The components packaged in this kit have been assembled and machined for specific type of conversions. Modifications to any of the components will void any possible warranty or return privileges. If you do not fully understand modifications or changes that will be required to complete your conversion, we strongly recommend that you contact our sales department for more information. This instruction sheet is only to be used for the assembly of Advance Adapter components. We recommend that a service manual pertaining to your vehicle be obtained for specific torque values, wiring diagrams and other related equipment. These manuals are normally available at automotive dealerships and parts stores.

ADVANCE ADAPTERS INC.

P.O. Box 247, 4320 Aerotech Center Way
Paso Robles, CA 93447

Telephone: (800) 350-2223 Fax: (805) 238-4201

P/N: 715596

New Item: (11/10)

PAGE 2 of 7

Page Rev. Date: 09-14-12

JKCABLE SHIFT LINKAGE UPGRADE KIT

The installation will require the disassembly of the console for 2007 to 2010 JK's. There are 4 bolts that hold the console in place; two of the bolts require the seats to be adjusted forward.

2011 & Up console removal: Pull the shifter knob straight up and off. The console is snap clipped into the lower console housing and the top portion just needs to be removed for the shifter installation



The stock transfer case shift knob must also be removed to remove the console. This knob is removed by pulling upward on the knob (it is a tight fit).



SPECIAL NOTE: The components packaged in this kit have been assembled and machined for specific type of conversions. Modifications to any of the components will void any possible warranty or return privileges. If you do not fully understand modifications or changes that will be required to complete your conversion, we strongly recommend that you contact our sales department for more information. This instruction sheet is only to be used for the assembly of Advance Adapter components. We recommend that a service manual pertaining to your vehicle be obtained for specific torque values, wiring diagrams and other related equipment. These manuals are normally available at automotive dealerships and parts stores.

ADVANCE ADAPTERS INC.

P.O. Box 247, 4320 Aerotech Center Way
Paso Robles, CA 93447

Telephone: (800) 350-2223 Fax: (805) 238-4201

P/N: 715596

New Item: (11/10)

PAGE 3 of 7

Page Rev. Date: 07-18-14

JKCABLE SHIFT LINKAGE UPGRADE KIT

Once the console is removed, you can unbolt the transfer case shifter from the floorboard and disconnect the stock cable from the shifter assembly. The stock cable extends forward and then into a access hole that goes along side the drivetrain.



Once the cable is along side the transmission, it gets routed back to a bracket that supports the cable, and then the cable connects to the transfer case shifter lever. The upgrade kit will require that the cable is removed. The stock cable support bracket is re-used.



New cable routed along the transmission JK's 2007-11.

SPECIAL NOTE: The components packaged in this kit have been assembled and machined for specific type of conversions. Modifications to any of the components will void any possible warranty or return privileges. If you do not fully understand modifications or changes that will be required to complete your conversion, we strongly recommend that you contact our sales department for more information. This instruction sheet is only to be used for the assembly of Advance Adapter components. We recommend that a service manual pertaining to your vehicle be obtained for specific torque values, wiring diagrams and other related equipment. These manuals are normally available at automotive dealerships and parts stores.

ADVANCE ADAPTERS INC.

P.O. Box 247, 4320 Aerotech Center Way
Paso Robles, CA 93447

Telephone: (800) 350-2223 Fax: (805) 238-4201

P/N: 715596

New Item: (11/10)

PAGE 4 of 7

Page Rev. Date: 09-14-12

JKCABLE SHIFT LINKAGE UPGRADE KIT

The shifter kits comes with a new shifter lever for the transfer case. The lever must be installed to achieve the proper throw on the linkage. Unfortunately, the NP241 Rocktrac transfer case design does not allow you access to the #40 torx bit without removing the transfer case front yoke (NP241 with the 2:72:1 low does not require the yoke to be removed). This also means you have to remove the front driveshaft at the transfer case. Once the yoke is removed and the lever bolt is removed, install the new lever on the transfer case with the supplied 8mm bolt and 1/4" flat washer.



The new cable can now start to be installed. First, the (2) 5/8" flat washers must be installed between the large nuts on the cable as shown. Next, equip the new cable with a heim joint and tighten the jam nut. Slide the cable into the stock bracket with a nut and washer on each side of the bracket. You can now install the cable up through the hole in the floorboard and into the cab. NOTE: If you desire to retain the stock floorboard rubber grommets (and it is recommended) that were used on the factory cable, then you must cut the stock cable in half and remove the grommet and then install it onto the new cable before feeding it through the floorboard.

LEVER MUST FIT TO THE T/C WITH THIS SIDE OUT.



Cable adjustment to transfer case:

NP241 Rocktrac transfer cases the heim is bolted to the outside of the shift lever with the 1/4"-20 x 1" bolt and lock nut. On the non-Rubicon NP241, the heim joint bolts to the outside of the shift lever with the addition of the 1/2" spacer between the heim joint and the T/C lever. Use the 1/4"-20 x 1-1/2" bolt and lock nut.

Adjust the linkage so that the heim joint travels approximately 1/8" past the lever in 2 high and 4 low.

On the Rubicon applications, reinstall the transfer case yoke. We recommend the use of black RTV silicone to the splines of the yoke (about a 1/4" bead) to prevent leakage. Install the new nut supplied in the kit and torque to 150 ft.-lbs.

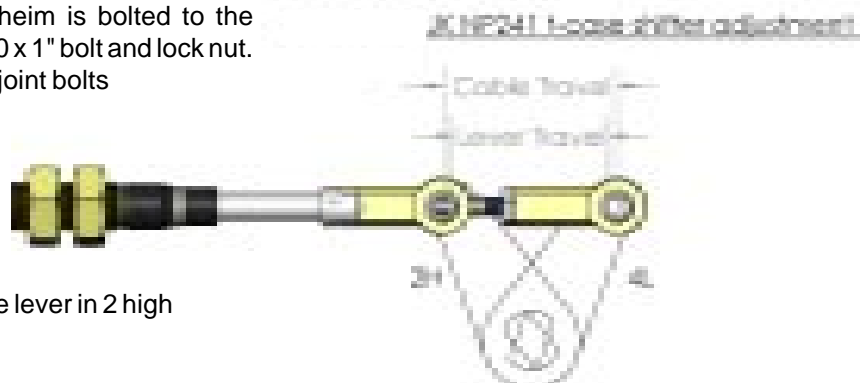

Adjust cable so that heim joint travels approximately 1/8" past lever hole in 2H and 4L.

SPECIAL NOTE: The components packaged in this kit have been assembled and machined for specific type of conversions. Modifications to any of the components will void any possible warranty or return privileges. If you do not fully understand modifications or changes that will be required to complete your conversion, we strongly recommend that you contact our sales department for more information. This instruction sheet is only to be used for the assembly of Advance Adapter components. We recommend that a service manual pertaining to your vehicle be obtained for specific torque values, wiring diagrams and other related equipment. These manuals are normally available at automotive dealerships and parts stores.

ADVANCE ADAPTERS INC.

P.O. Box 247, 4320 Aerotech Center Way
Paso Robles, CA 93447

Telephone: (800) 350-2223 Fax: (805) 238-4201

P/N: 715596

New Item: (11/10)

PAGE 5 of 7

Page Rev. Date: 10-11-10

JKCABLE SHIFT LINKAGE UPGRADE KIT

Shifter Modifications: The shifter assembly needs to be disassembled to install the new stronger shifter components. The plastic shifter cover is removed by slipping a straight screw driver under its edge and lifting gently. The shift handle pivot pin can be removed by tapping the pin several times with a small hammer or mallet.

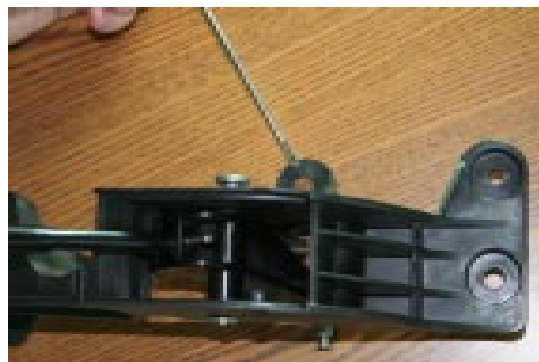

After the pivot pin is removed, you should be able to remove the handle assembly. The handle has a pivot pin that also must be pressed out. Be careful not to loose the spring and bushing when pulling the plastic assembly from the handle. We found that a 7/16" -1/4" drive socket works great to press the handle pin from the handle.



SPECIAL NOTE: The components packaged in this kit have been assembled and machined for specific type of conversions. Modifications to any of the components will void any possible warranty or return privileges. If you do not fully understand modifications or changes that will be required to complete your conversion, we strongly recommend that you contact our sales department for more information. This instruction sheet is only to be used for the assembly of Advance Adapter components. We recommend that a service manual pertaining to your vehicle be obtained for specific torque values, wiring diagrams and other related equipment. These manuals are normally available at automotive dealerships and parts stores.

ADVANCE ADAPTERS INC.

P.O. Box 247, 4320 Aerotech Center Way
Paso Robles, CA 93447

Telephone: (800) 350-2223 Fax: (805) 238-4201

P/N: 715596

New Item: (11/10)

PAGE 6 of 7

Page Rev. Date: 10-11-10

JKCABLE SHIFT LINKAGE UPGRADE KIT

Slip the aluminum housing on to the JK handle and reinstall the pin that was just removed. Be sure that the upper handle leans back towards the 1/2" hole in the aluminum housing.



Install the stock spring and spring bushing from the old assembly into the new (gold bracket) and mount to the aluminum housing using the supplied 1/4"-20 x 5/8" button head bolts.



Reinstall the handle assembly back into the shifter housing and reinstall the stock pivot pin and clip. Loosely bolt the new cable mounting bracket to the stock shifter housing using the 1/4"-20 x 3/4" S.H.S.C. Align the back edge of the bracket with the shifter housing so they are parallel. Tighten the bracket to the housing. Drill two 1/4" holes using the bracket as a template. Secure the bracket with the other two bolts.



SPECIAL NOTE: The components packaged in this kit have been assembled and machined for specific type of conversions. Modifications to any of the components will void any possible warranty or return privileges. If you do not fully understand modifications or changes that will be required to complete your conversion, we strongly recommend that you contact our sales department for more information. This instruction sheet is only to be used for the assembly of Advance Adapter components. We recommend that a service manual pertaining to your vehicle be obtained for specific torque values, wiring diagrams and other related equipment. These manuals are normally available at automotive dealerships and parts stores.

ADVANCE ADAPTERS INC.

P.O. Box 247, 4320 Aerotech Center Way
Paso Robles, CA 93447

Telephone: (800) 350-2223 Fax: (805) 238-4201

P/N: 715596

New Item: (11/10)

PAGE 7 of 7

Page Rev. Date: 10-11-10

JKCABLE SHIFT LINKAGE UPGRADE KIT

Loosely attach the cable to the shifter housing. Bolt the housing to the floor with the stock nuts. Install the new heim joint to the cable and secure it with the jam nut. Adjust the linkage as shown in the drawing. Bolt the heim to the new lever assembly with the 1/4"-20 x 1" H.H.C.S. and locknut.

Shift the transfer case to ensure the cable is adjusted correctly and that you have all transfer case ranges.

Reattach the transfer case shifter cover. Reinstall the console and shifter knob.

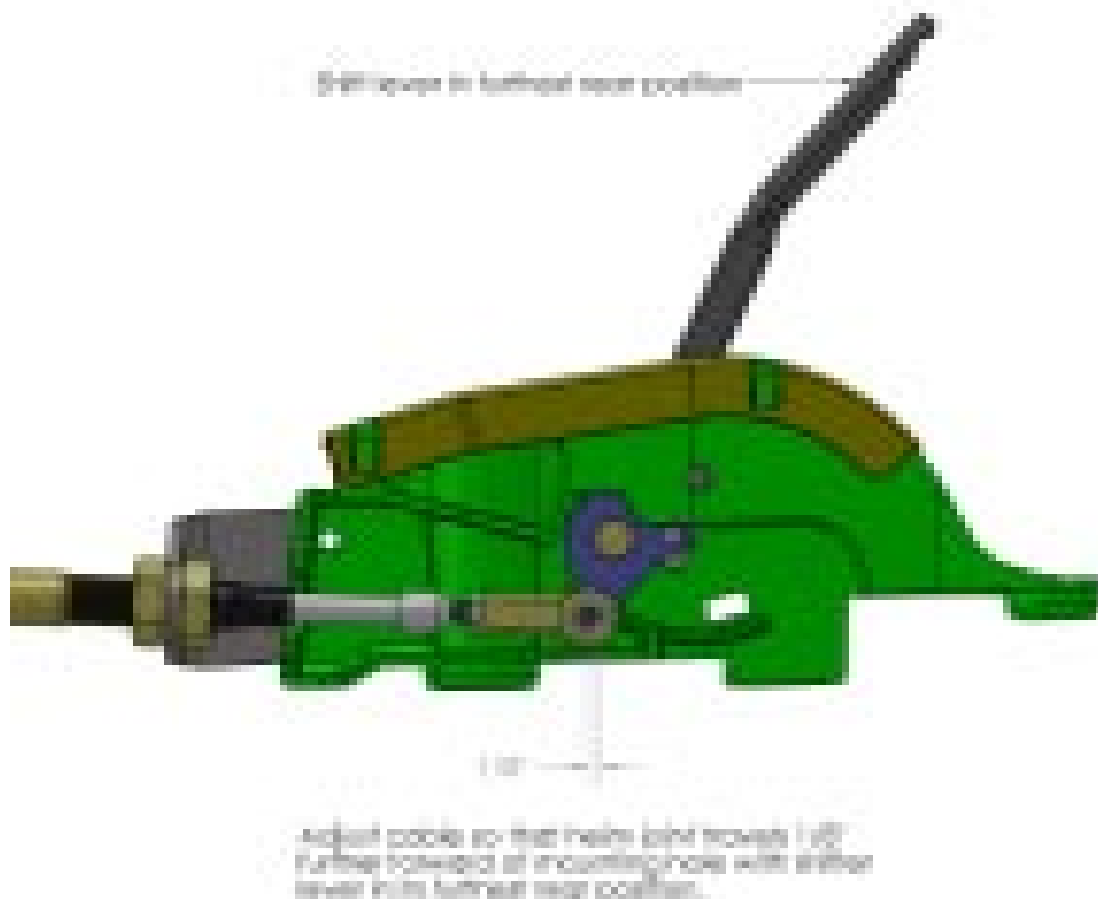

SPECIAL NOTE: The components packaged in this kit have been assembled and machined for specific type of conversions. Modifications to any of the components will void any possible warranty or return privileges. If you do not fully understand modifications or changes that will be required to complete your conversion, we strongly recommend that you contact our sales department for more information. This instruction sheet is only to be used for the assembly of Advance Adapter components. We recommend that a service manual pertaining to your vehicle be obtained for specific torque values, wiring diagrams and other related equipment. These manuals are normally available at automotive dealerships and parts stores.